



US 20050012091A1

(19) **United States**

(12) **Patent Application Publication**  
**Huang**

(10) **Pub. No.: US 2005/0012091 A1**

(43) **Pub. Date: Jan. 20, 2005**

(54) **ACTIVE MATRIX ORGANIC  
ELECTROLUMINESCENCE DISPLAY  
DEVICE**

(30) **Foreign Application Priority Data**

Jul. 18, 2003 (TW)..... 92119704

**Publication Classification**

(51) **Int. Cl.<sup>7</sup>** ..... **H01L 35/24**

(52) **U.S. Cl.** ..... **257/40**

(75) **Inventor: Wei-Pang Huang, Hsinchu City (TW)**

Correspondence Address:  
**BRUCE H. TROXELL  
SUITE 1404  
5205 LEESBURG PIKE  
FALLS CHURCH, VA 22041 (US)**

(57) **ABSTRACT**

An active matrix organic electroluminescence display device capable of maintaining the brightness of the organic light emitting diode. The active matrix organic electroluminescence display device comprises a thin film transistor and an organic light emitting diode. By improving the structure of the passivation layer of the thin film transistor to reduce the leakage current occurring in the TFT, the brightness of the organic light emitting diode can be stably maintained.

(73) **Assignee: AU Optronics Corp.**

(21) **Appl. No.: 10/691,640**

(22) **Filed: Oct. 24, 2003**

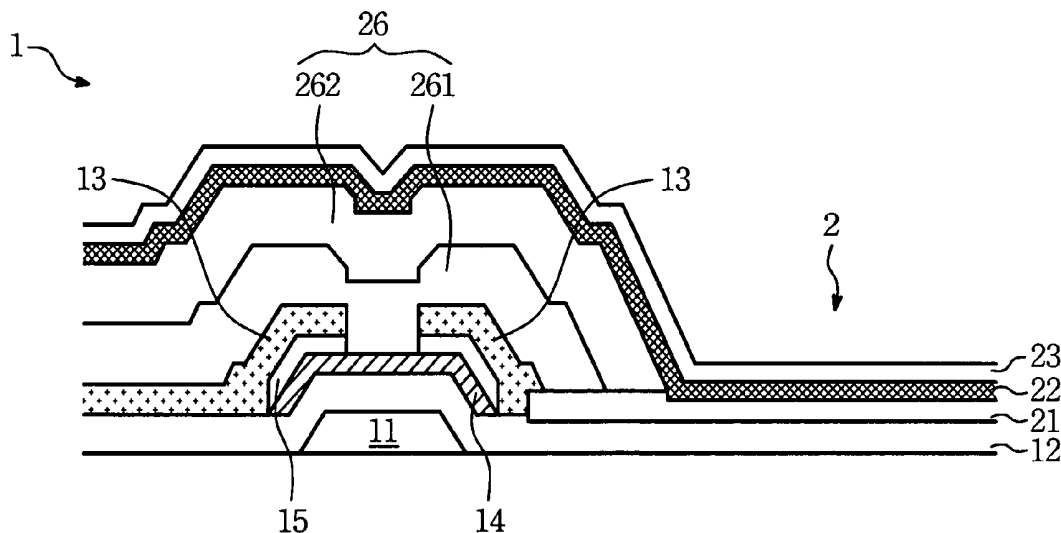

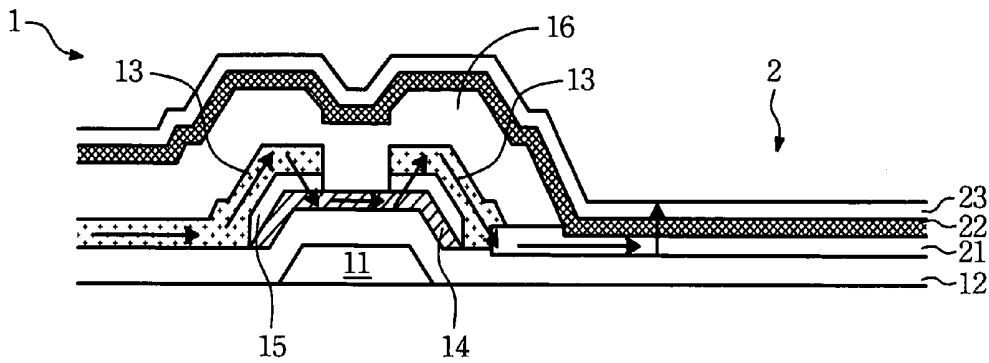

FIG. 1  
(Prior Art)

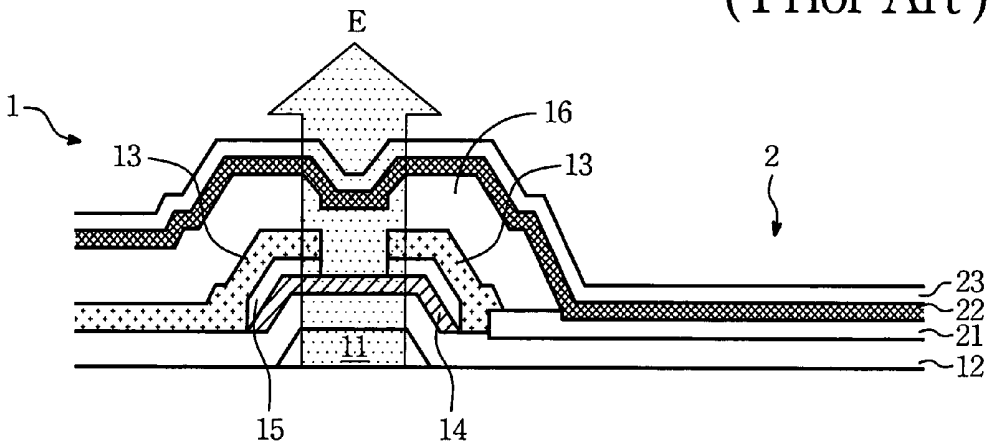

FIG. 2  
(Prior Art)

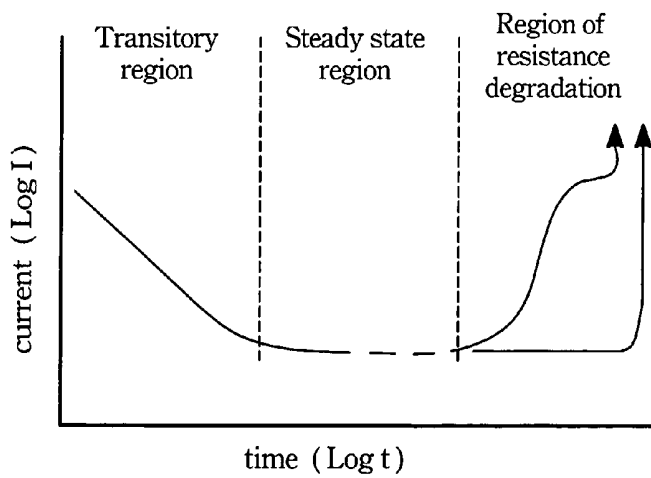

FIG. 3  
(Prior Art)

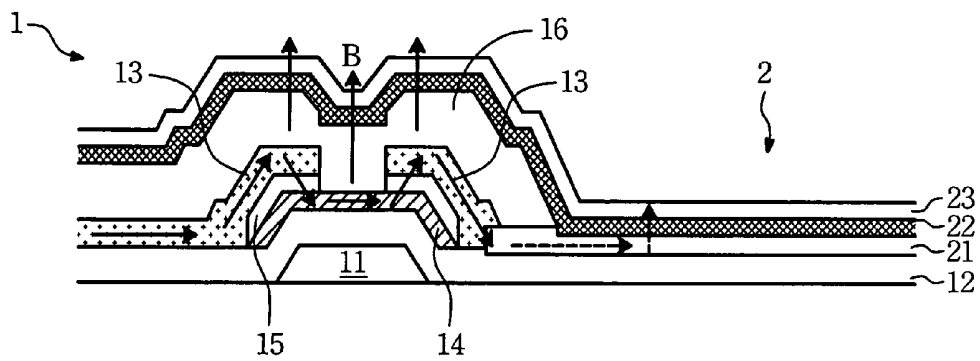

FIG. 4  
(Prior Art)

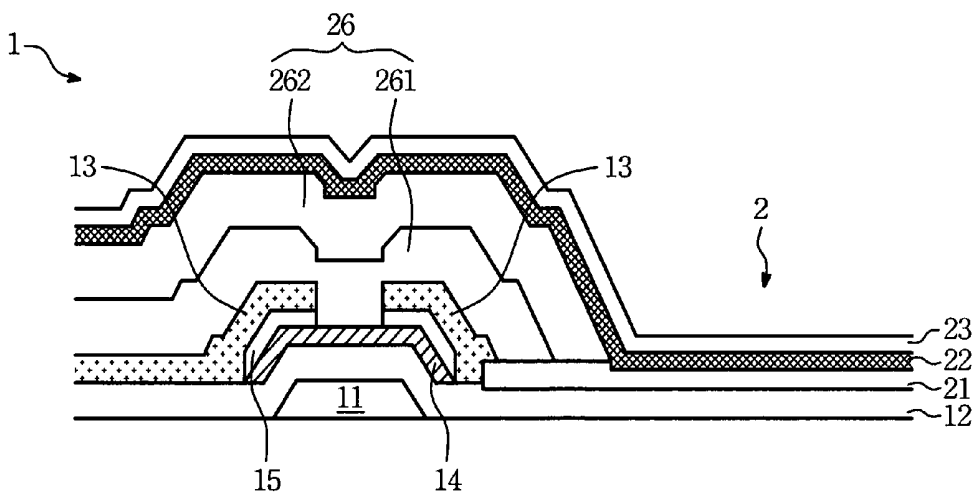

FIG. 5

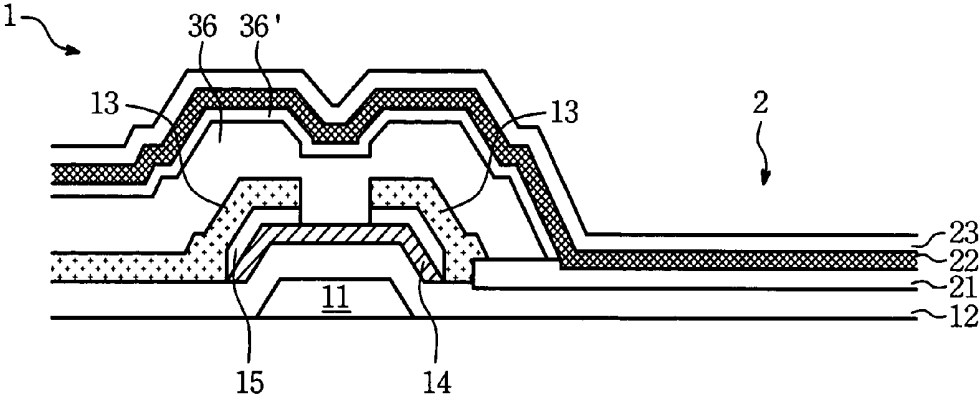

FIG. 6

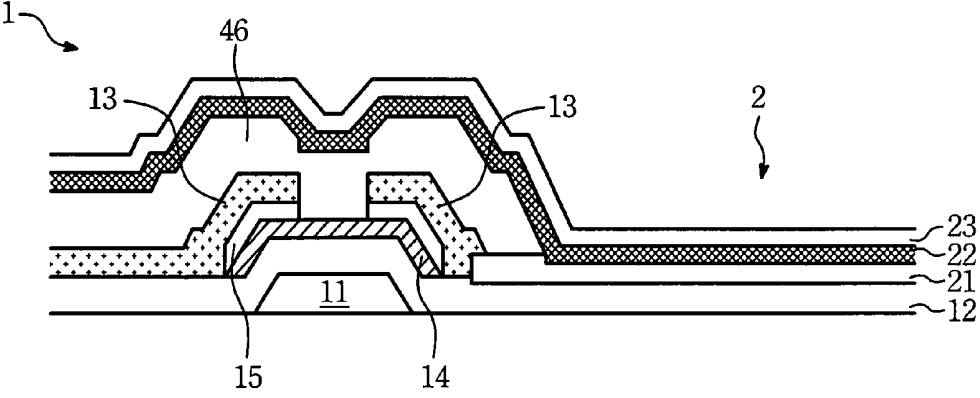

FIG. 7

## ACTIVE MATRIX ORGANIC ELECTROLUMINESCENCE DISPLAY DEVICE

### FIELD OF THE INVENTION

[0001] The present invention relates to an organic electroluminescence display device and, more specifically, to a structure of an active matrix organic electroluminescence display device for reducing the leakage current occurring in the thin-film transistor so as to maintain the brightness of the organic light emitting diode.

### BACKGROUND OF THE INVENTION

[0002] Owing to high brightness, fast response speed, light weight, thin and small features, full color, no viewing angle differences, no need for an LCD back-light board and low electrical consumption, an organic light emitting diode display or organic electroluminescence display (OLED) takes the lead to substitute a twist nematic (TN) or a super twist nematic (STN) liquid crystal display. Further, it substitutes for a small-sized thin-film transistor (TFT) LCD to become a new display material of fabricating portable information products, cell phones, personal digital assistant (PDA) and notebook.

[0003] The organic light emitting diode display comprises passive matrix organic light emitting diode displays (PMOLED) and active matrix organic light emitting diode displays (AMOLED). Thin film transistors in combination with signals of a storage capacitor are used in the AMOLED to control the gray scale presentation of the organic light emitting diode. After the scan line sweeps, the original brightness of the pixels is still maintained. However, for the PMOLEDs, only the pixels selected by the scan line will be lighted. Hence, it is not necessary to drive the organic light emitting diodes in the AMOLED to the very high brightness, and the AMOLED has a long lifetime and a high resolution.

[0004] Please refer to **FIG. 1**, which is a schematic side view of a structure of the AMOLED. The thin film transistor 1 of the AMOLED includes a gate metal 11, a dielectric insulation layer 12, a source/drain metal 13, an amorphous silicon layer 14, a doped amorphous silicon 15 and a passivation layer 16. The organic light emitting diode 2 of the AMOLED includes an indium tin oxide (ITO) electrode 21, an organic emitting layer 22 and a cathode electrode 23. The ITO electrode 21 is connected to the source/drain metal 13. Since the AMOLED is a current-driven element, a given current has to be provided to maintain the consistent brightness of the organic light emitting diodes.

[0005] As shown in **FIG. 1**, the current passes the source/drain metal 13 of the TFT 1 through the ITO electrode 21 and flows into the organic emitting layer 22 and the cathode electrode 23, as shown in the direction of the arrows, and then the organic light emitting diode radiate light. However, in the current technology, the brightness of the organic light emitting diode decays when the given current is provided. Therefore, it is desired to find out the causes of the unstable brightness of the AMOLED and to improve the structure of the AMOLED so as to fabricate an AMOLED capable of maintaining the brightness of the organic light emitting diode.

### SUMMARY OF THE INVENTION

[0006] An object of the present invention is to provide an active matrix organic electroluminescence display device

capable of maintaining the brightness of the organic light emitting diode. By improving the structure of the passivation layer of the thin film transistor to reduce the leakage current occurring in the TFT, the brightness of the organic light emitting diode can be stably maintained.

[0007] A structure of an active matrix organic electroluminescence display device with the stable emitting brightness is disclosed in this invention. The active matrix organic electroluminescence display device comprises a thin film transistor and an organic light emitting diode, wherein the passivation layer of the thin film transistor is a multi-layer structure. The thickness of the multi-layer structure is more than that of a conventional passivation layer, and each layer of the multi-layer structure can be made of a different dielectric material.

[0008] In another embodiment of this invention, the surface of the passivation layer of the thin film transistor of the AMOLED is thermally oxidized.

[0009] In still another embodiment of this invention, the passivation layer of the thin film transistor of the AMOLED is made of a high dielectric material.

### BRIEF DESCRIPTION OF THE DRAWINGS

[0010] The foregoing aspects and many of the attendant advantages of this invention will become more readily appreciated as the same becomes better understood by reference to the following detailed description, when taken in conjunction with the accompanying drawings, wherein:

[0011] **FIG. 1** is a schematic side view of a structure of the conventional active matrix organic light emitting diode display (AMOLED);

[0012] **FIG. 2** shows a strong electric field between the gate metal and the cathode electrode of the AMOLED in **FIG. 1**;

[0013] **FIG. 3** is a diagram showing the variation of a current flowing a dielectric material in a given voltage with respect to time;

[0014] **FIG. 4** shows a large amount of leakage current flowing out from the passivation layer of the AMOLED in **FIG. 1**;

[0015] **FIG. 5** is a schematic side view of a structure of the passivation layer of the TFT of the AMOLED in accordance with a first embodiment of this invention;

[0016] **FIG. 6** is a schematic side view of a structure of the passivation layer of the TFT of the AMOLED in accordance with a second embodiment of this invention; and

[0017] **FIG. 7** is a schematic side view of a structure of the passivation layer of the TFT of the AMOLED in accordance with a third embodiment of this invention.

### DETAILED DESCRIPTION OF THE PREFERRED EMBODIMENTS

[0018] A structure of an active matrix organic electroluminescence display device capable of maintaining the stable emitting brightness is provided in this invention. According to researches, the cause of the unstable brightness of the AMOLED is found. When the TFT 1 of the AMOLED operates, a voltage is applied on the gate metal 11 and there

is a strong electric field E between the gate metal **11** and the cathode electrode **23**, as shown in **FIG. 2**. The passivation layer **16** of the TFT **1** is made of a dielectric material such as SiNx.

[0019] **FIG. 3** shows the variation of a current flowing through a given dielectric material in a given voltage with respect to time. When the current-resistant ability of the passivation layer **16** is poor, a breakdown will occur in the passivation layer **16** after a certain period and a large amount of leakage current flows out from the passivation layer **16**, as shown by the arrow B in **FIG. 4**. Even though a given current is provided, the current flowing through the ITO electrode into the organic emitting layer **22** is greatly reduced to result in the brightness decay of the organic light emitting diode. Therefore, in order to reduce the occurrence of the leakage current, to have the given current provided effectively pass the organic light emitting diode rather than flow out from the other pathways, and thus to maintain the brightness of the organic light emitting diode and to increase the lifetime of the AMOLED element, the structure of the passivation layer of the TFT is improved in this invention.

[0020] Refer to **FIG. 5**, which is a schematic side view of a structure of the passivation layer of the TFT of the AMOLED in accordance with a first embodiment of this invention. A passivation layer **26** of a multi-layer structure is fabricated to enhance the current-leakage resistant ability of the passivation layer **26**. For instance, at least two-layer SiNx is plated, each layer of which is in a 3000 Å thickness. Alternatively, one layer of the at least two-layer structure is made of SiNx and another layer is made of the other dielectric material. As shown in **FIG. 5**, the passivation layer **26** is composed by a two-layer structure **261**, **262**. The current-leakage resistant ability of the passivation layer **26** can be doubly enhanced by increasing the thickness of the dielectric layer of the passivation layer and increasing the interface between the dielectric layers because of multi-layer plating.

[0021] Furthermore, the surface of the passivation layer can also be treated by thermal oxidation in this invention to enhance the current-leakage resistant ability of the passivation layer. **FIG. 6** is a schematic side view of a structure of the passivation layer of the TFT of the AMOLED in accordance with a second embodiment of this invention. For instance, after a SiNx passivation layer **36** is plated, the SiNx layer is in a thermal oxidation treatment and SiON is formed on the surface **36'** of the passivation layer **36** to enhance the current-leakage resistant ability of the passivation layer.

[0022] In addition, **FIG. 7** is a schematic side view of a structure of the passivation layer of the TFT of the AMOLED in accordance with a third embodiment of this invention. A high dielectric material such as SiO<sub>2</sub> can be used to fabricate a passivation layer **46** to enhance the current-leakage resistant ability of the passivation layer.

[0023] As is understood by a person skilled in the art, the foregoing preferred embodiments of the present invention are illustrated of the present invention rather than limiting of the present invention. It is intended to cover various modifications and similar arrangements included within the spirit and scope of the appended claims, the scope of which should be accorded the broadest interpretation so as to encompass all such modifications and similar structure.

What is claimed:

1. An active matrix organic electroluminescence display device, comprising:

a thin film transistor, comprising:

a gate metal disposed on a substrate;

a dielectric insulation layer covering said gate metal and said substrate;

a source/drain metal disposed on said dielectric insulation layer and above said gate metal; and

a passivation layer covering said source/drain metal and being a multi-layer structure; and

an organic light emitting diode, comprising:

an anode electrode connected to said source/drain metal;

an organic emitting layer formed on said anode electrode; and

a cathode electrode formed on said organic emitting layer.

2. The active matrix organic electroluminescence display device of claim 1, wherein each layer of said multi-layer structure is made of a different dielectric material.

3. An active matrix organic electroluminescence display device, comprising:

a thin film transistor, comprising:

a gate metal disposed on a substrate;

a dielectric insulation layer covering said gate metal and said substrate;

a source/drain metal disposed on said dielectric insulation layer and above said gate metal; and

a passivation layer covering said source/drain metal, wherein the surface of said passivation layer is thermally oxidized; and

an organic light emitting diode, comprising:

an anode electrode connected to said source/drain metal;

an organic emitting layer formed on said anode electrode; and

a cathode electrode formed on said organic emitting layer.

4. The active matrix organic electroluminescence display device of claim 3, wherein said passivation layer is made of SiNx and the surface thereof is thermally oxidized to form SiON.

5. An active matrix organic electroluminescence display device, comprising:

a thin film transistor, comprising:

a gate metal disposed on a substrate;

a dielectric insulation layer covering said gate metal and said substrate;

a source/drain metal disposed on said dielectric insulation layer and above said gate metal; and

a passivation layer covering said source/drain metal and composed by a high dielectric material; and

an organic light emitting diode, comprising:

an anode electrode connected to said source/drain metal;

an organic emitting layer formed on said anode electrode; and

a cathode electrode formed on said organic emitting layer.

6. The active matrix organic electroluminescence display device of claim 5, wherein said passivation layer is made of SiO<sub>2</sub>.

\* \* \* \* \*

专利名称(译)	有源矩阵有机电致发光显示装置		
公开(公告)号	<a href="#">US20050012091A1</a>	公开(公告)日	2005-01-20
申请号	US10/691640	申请日	2003-10-24
[标]申请(专利权)人(译)	友达光电股份有限公司		
申请(专利权)人(译)	友达光电.		
当前申请(专利权)人(译)	友达光电.		
[标]发明人	HUANG WEI PANG		
发明人	HUANG, WEI-PANG		
IPC分类号	H01L27/32 H01L35/24		
CPC分类号	H01L27/3246 H01L27/1248 H01L27/3258 H01L27/3248		
优先权	092119704 2003-07-18 TW		
其他公开文献	US6992325		
外部链接	<a href="#">Espacenet</a> <a href="#">USPTO</a>		

摘要(译)

一种有源矩阵有机电致发光显示装置，能够保持有机发光二极管的亮度。有源矩阵有机电致发光显示装置包括薄膜晶体管和有机发光二极管。通过改善薄膜晶体管的钝化层的结构以减少TFT中发生的漏电流，可以稳定地保持有机发光二极管的亮度。

